

Quick Installation Guide

LP KTL-S 33kW

Attention: Only trained electrically qualified personnel are permitted to do electrical operation on this product!

Step 1: Packing List Check

► Check if the packaging is intact and the accessories are complete.

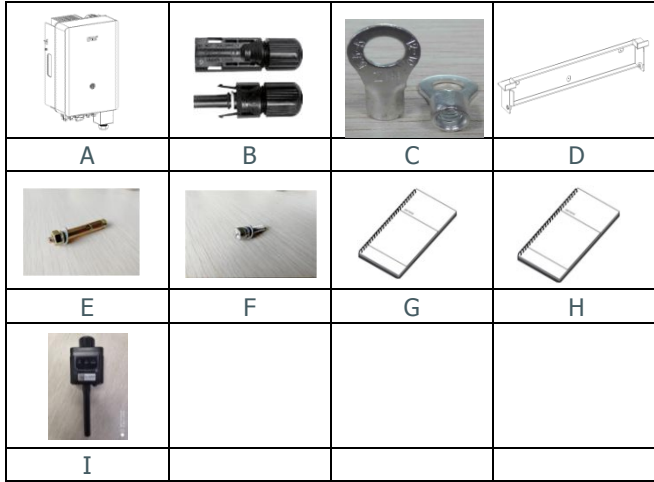

A	Grid-Connected PV Inverter	1pc
B	PV input terminal	1set
C	AC wiring copper nose	5pcs
D	Wall mounting bracket	1pc
E	Expansion screw	3pcs
F	Cross hexagon double pads screw M6X20	2pcs
G	User Manual	1copy (PDF)
H	Quick Installation Guide	1copy
I	Communication module (WIFI&GPRS)	1pc

Note: Please download the User Manual from the company website:

www.eastups.com

► Check if every machine module is intact.

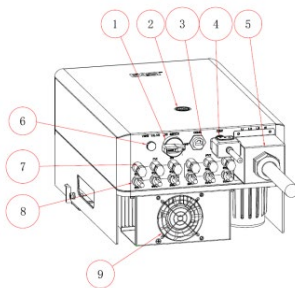

	Description	Remarks
1	DC switch (option)	To control DC input on and off directly
2	LED display panel	To display the inverter running state/communication status
3	Electric meter & DRM communication	User electric meter communication & DRM (demand response mode) interface
4	WIFI&GPRS communication terminal	To connect WiFi or GPRS communication module
5	AC output terminal	To feed the inverter output energy into the grid
6	Ventilation valve	To prevent from condensing and fogging, and balance differential pressure inside and outside the cabinet
7	PV+ input terminal	To connect the positive electrode of the PV module
8	PV- input terminal	To connect the negative electrode of the PV module
9	Cooling fan	To fan cooling the inverter

Step 2: Machine Installation

► Choose a well-ventilated, no direct sunlight, no rain and snow installation location. It is recommended to be installed in the place such as indoor garage or loft.



► Select a wall with sufficient space and defined angle.

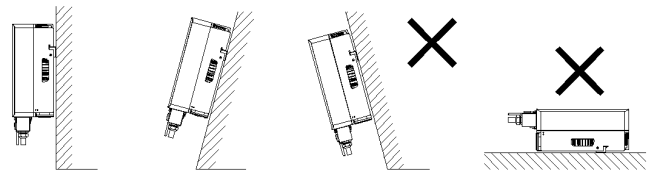

Note: Installed vertically or tilted backward no more than 15°, no lateral tilt or horizontal installation, wiring area should face downward.

► For good heat dissipation and easy disassembly, the minimum clearance around the inverter must not be less than the following values.

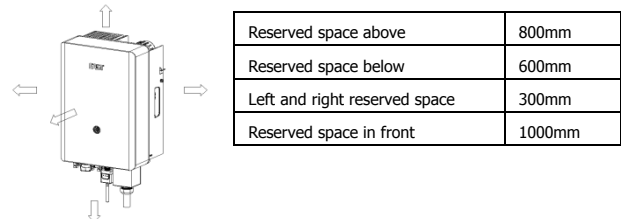

► Mark the position of clevis mounting holes on the wall. According to the specifications of the expansion screw, use an electric screwdriver to drill suitable mounting holes at the marks, and then fix the clevis to the wall.

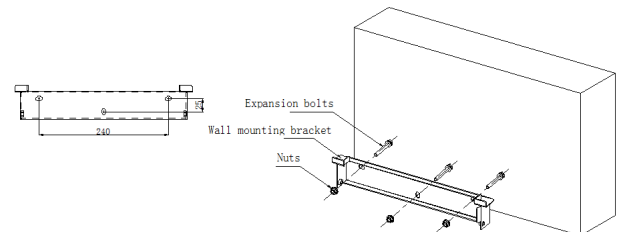

Horizontal distance	240mm
Vertical distance	25mm
Drilling diameter	6mm
Drilling depth	50mm

► Align the inverter radiator mounting holes with the clevis and push it to the bottom, then hang it in line. Fasten the left and right sides of the clevis to the inverter bracket by using the screws provided respectively.

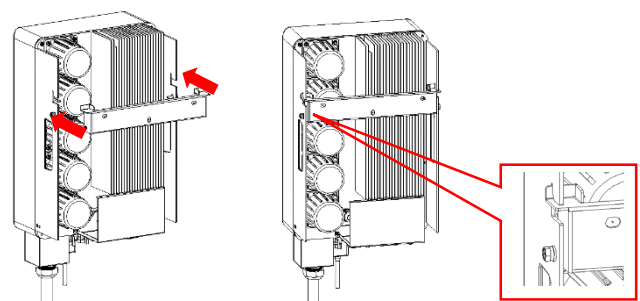

Quick Installation Guide

LP KTL-S 33kW

Step 3: AC Side Wiring

Attention: Before wiring, make sure the circuit breaker on the AC side is disconnected until the PV system fully installed!

Attention: If the user adds a residual current detector to the AC side, it is recommended a 300mA type B residual current detector!

Wiring cable requirement: **Since the peak current of AC short circuit measurement can reach 240A, please be sure to strictly follow the requirements of wiring and use the specified wire diameter of the cable.**

Cable	Cable dimension (mm ²)
PV input end	Recommend wire diameter 4~6mm ²
AC output L1 phase	15-25KW recommend wire diameter 10mm ² 30-33KW recommend wire diameter 16mm ²
AC output L2 phase	15-25KW recommend wire diameter 10mm ² 30-33KW recommend wire diameter 16mm ²
AC output L3 phase	15-25KW recommend wire diameter 10 mm ² 30-33KW recommend wire diameter 16mm ²
AC output N phase	15-25KW recommend wire diameter 10mm ² 30-33KW recommend wire diameter 16mm ²
Grounding cable	Recommend wire diameter 6~8mm ²

- ▶ Strip the DC cable insulation layer of about 8mm to reveal the copper wire.



- ▶ Pass the appropriate length of cable through the waterproof joint end shield and the case. Insert the copper wire of the cable into the RNB terminal and press it tightly with crimping pliers.

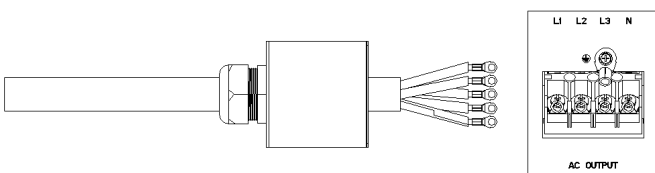

- ▶ Use a screwdriver to fix L1, L2, L3, N, PE wire to the corresponding AC wiring terminal, ensure that the PE wire is reliably grounded, then lock the outlet box, and finally tighten the waterproof joint end shield.

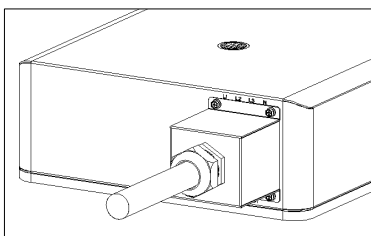

Step 4: DC Side Wiring

Attention: Before installing, make sure the inverter DC switch is off, until the PV system installed.

Attention: High DC voltage will be generated when the solar panels are sunlit. Please be careful to take appropriate protective measures!

- ▶ Strip the DC cable insulation layer of about 8mm to reveal the copper wire.

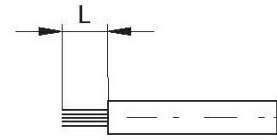

- ▶ Insert the copper wire of the cable into the metal core of the connector and compress it with a crimping pliers, loosen the terminal cover, and pass the cable through the terminal cover. Insert the core into the wiring slot until you hear the sound of connection in place.

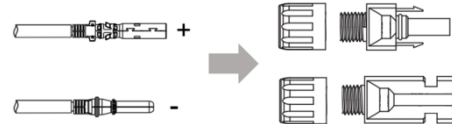

- ▶ Tighten the terminal cover to ensure well waterproof performance. Connect the PV DC input connector to the corresponding polarity DC input port of the inverter until a slight "click" is heard.

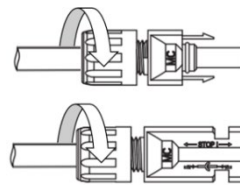

Attention: Use a voltmeter with DC voltage range over 1000V to check whether the wiring of polarity of PV array cable is correct and confirm that the open circuit voltage does not exceed the specification. When the ambient temperature is higher than 10°C, the PV array open circuit voltage should not exceed 90% of the maximum DC voltage of the inverter, otherwise at low temperature, the PV array voltage may exceed the maximum input voltage of the inverter and cause damage.

- ▶ Connect the PV DC input connector to the corresponding polarity DC input port of the inverter until a slight "click" is heard.

Step 5: Grounding Protection Connection

- ▶ A protective grounding hole is right at the bottom of the inverter chassis. User must ground the inverter through the grounding hole and fasten it with supplied M6*10 screws.

Attention: PE wiring on the AC side cannot replace this grounding protection, so make sure that both are reliably grounded.

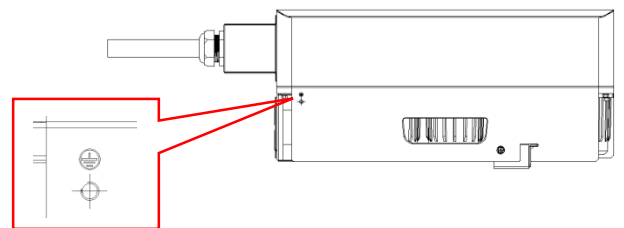

Step 6: Communication Connection

- ▶ Plug the WIFI module, GPRS module or Ethernet communication module into the COM1 communication interface, and then tighten the fixing nut.
- ▶ Plug the RJ45 plug for meter communication and switching value input into the COM2 connector at the bottom of the chassis, for meter wiring, please refer to the User Manual.

Step 7: Start the Machine

- ▶ Check that all parts of the PV system are installed correctly and firmly.
- ▶ Machine perform start-up detection (more than one minute), after the self-test passed, the machine will automatically run, output power to the grid, the green LED indicator is always on.

Note: Please refer to the User Manual for precautions